



**RELIABLE BEYOND LIMITS**

# ABOUT ABC COMPRESSORS

Since its **foundation in 1943**, ABC has focused on providing **the most reliable compressors for different sectors and applications**. Its **global orientation** and the commitment for growth was shown from its early exports in the 50's to its latest geographical expansion, having delivered compressors in more than 120 countries.

Becoming a worldwide **benchmark in the piston compressor industry** has always been ABC's goal, and today it has turned into reality. The company is continuously expanding and consolidating as a global solution supplier, with more robust and efficient compressors. New assembly plants in China and Brazil, and the endless opening of new service outlets worldwide are the **best proof of such growth**.

## MILESTONES

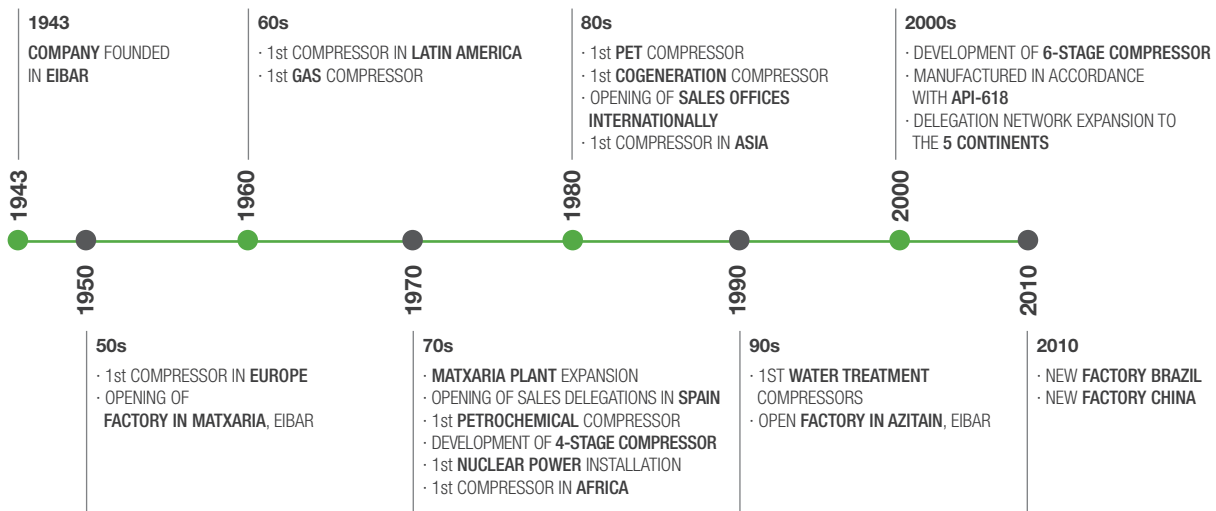

## PRODUCTION CAPACITY

Thanks to its production plants, ABC offers to its customers different supply alternatives. Without any compromise on the quality or guarantee, ABC can adapt to the customer

demands combining the production of main mechanical parts in the plant in Europe, with the different packaging and testing facilities in Europe, China and Brazil.

	ABC EIBAR	ABC WUJIANG	ABC ITUPEVA
ENGINEERING AND R&D&i	✓		
PROJECT MANAGEMENT	✓	✓	✓
MECHANIZATION	✓		
BARE COMPRESSOR ASSEMBLY	✓		
COMPRESSOR PACKAGE ASSEMBLY	✓	✓	✓
COMPRESSOR PACKAGE TESTING	✓	✓	✓



ABC HEADQUARTERS SPAIN  
EIBAR



ABC CHINA  
WUJIANG



ABC BRAZIL  
ITUPEVA

**PROJECT MANAGEMENT**



**SHORT DELIVERY TIME**



**CUSTOMISED CONFIGURATION**

Project Managers lead a team of mechanical and electronic experts, as well as applications engineers from ABC, throughout the whole process: from the design to start up.

Advanced engineering (Solidedge, AutoCAD, finite element analysis) and management tools (integrated ERP) are used.

The sales team, together with the Project Manager, work closely with both the technical staff from the client and the engineering companies, with the following targets:

- Analysis and study of the customer requirements**
- Configuration of compressor and auxiliary equipment**
- Definition of the electric and control diagrams**

After this detailed engineering step, the main documents (compressor assembly and foundation drawings, P&ID, electrical diagrams, instrumentation lists, etc.) are ready to be reviewed, if necessary, by the client or engineering contractor, and then, launched into production.

The quality begins with each piece and finishes with the guarantee of operation, by testing the whole compressor set.

That's why, all ABC production and assembly facilities are fitted with one test installation, with more than 1.000m<sup>2</sup>. Here, the operation and performance parameters of the machine are tested under real conditions based on customers' requirements.

In order to be able to test the whole compressor set before being supplied, the ABC Engineering Department integrates all auxiliary systems (lubrication, cooling, power supply, control, etc.) on a single skid.



100% testing ensures no surprises

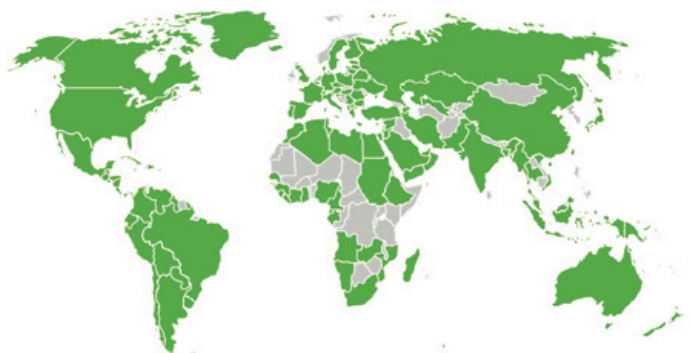

Compressors in more than 120 countries

# SOLUTIONS AND PRODUCT RANGE

ABC's compressors are designed to operate 24 hours a day, 365 days a year. Configured with up to 3 pairs of cylinders and up to 6 stages of compression, the loads on each element are so low that the machine can achieve an exceptionally **long service life**.

Additionally, the horizontally-opposed cylinder arrangement provides a balance of the compressor inertia, nullifying vibrations, and avoiding excessive wear and failures on the machine parts.

## AIR & GAS COMPRESSORS

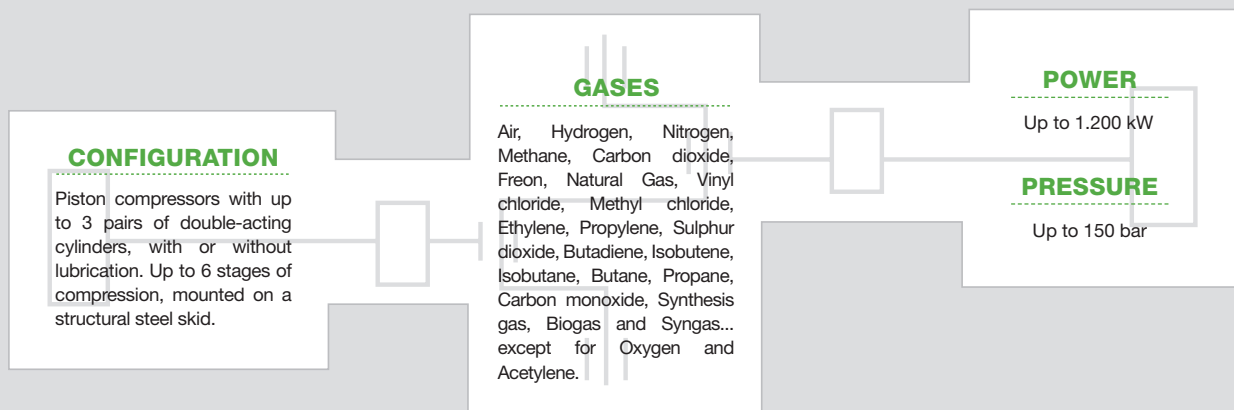

### RELIABILITY

- Up to 5 years of guarantee.
- 24 hours x 365 days of operation.
- Service starting from 8.000 hours.
- Minimum vibration and noise.



### EASY TO INSTALL

- Quick start up and mobility.
- No vibration isolation required.
- Reduced installation space.
- Training on site.



### ENERGY EFFICIENCY

- Market leader in kWh/Nm<sup>3</sup>.
- Lowest total cost of ownership.



### ENDURANCE

- Total guarantee and efficiency in extremely demanding conditions.
- Maximum part durability.

## REGULATIONS

- **European Directives:**  
97/23/CE, 2006/95/CE, 2004/108/CE, ATEX 94/9/CE, 2009/105/CE, 2006/42/CE
- **Design Standards:**  
AD2000, ASME, TEMA C, TEMA R, NEMA
- **Petrochemical Industry:**  
API (API 11P and API 618)

- **Chinese Legislation:**  
SELO
- **American Legislation:**  
U STAMP ASME
- **Russian Legislation:**  
TR (GOST R) + PASSPORT + RTN (ROSTEKHNADZOR)
- **Brazilian Legislation:**  
NR12 and NR13

**STATE OF ART COMPONENTS**



**PULSATION ANALYSIS**

API 618 approaches 1 to 3.

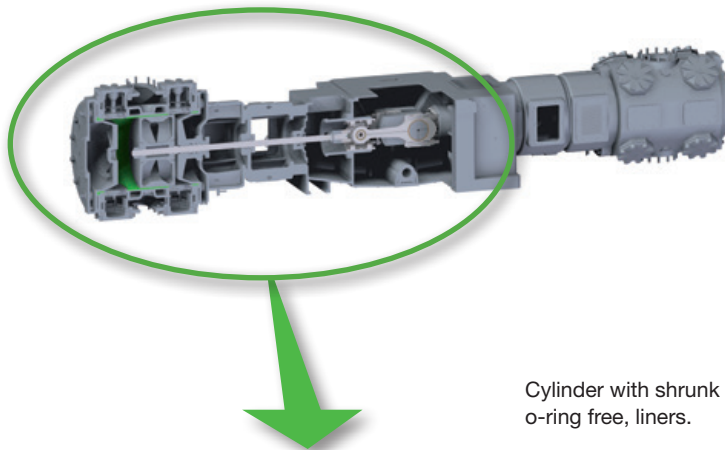
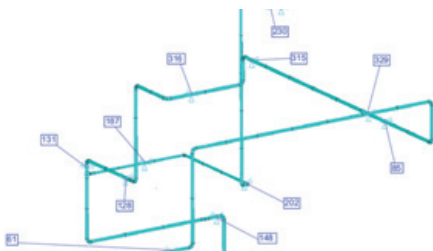

Cylinder with shrunk in, o-ring free, liners.

**1 PACKINGS**

Water cooled type without o-rings around the rod.

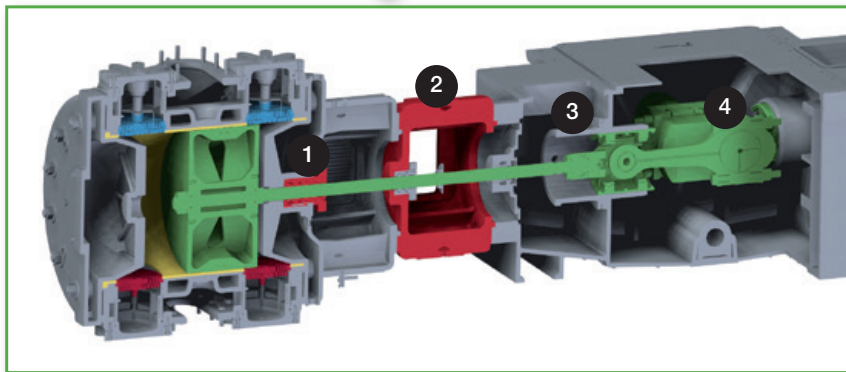
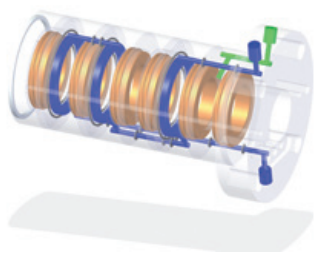

**2 DISTANCE PIECE**

API 618 types A, B or C.



**3 CROSSHEAD**

Cast steel with removable shoes and hydraulic tightning.



**4 FORGED CONROD**

With friction bearings and hydraulic tightnen nuts.

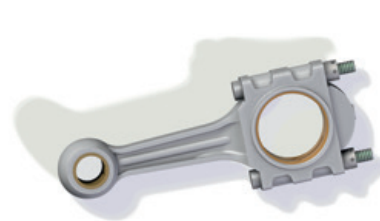

**CRANKCASE VALVES**

Pressure relief valves for explosion protection with flame arrester.

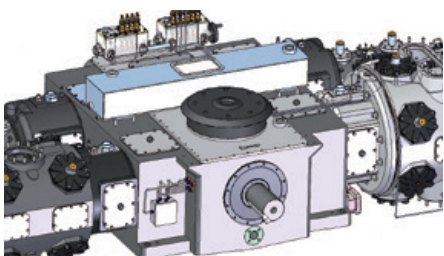

**FORGED CRANKSHAFT**

On all series, from one to six cylinders.

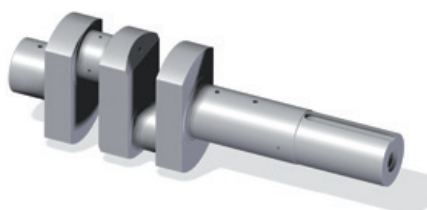

**INSTRUMENTATION**

For predictive maintenance: rod drop, P-V diagrams, temperatures, vibrations, etc.

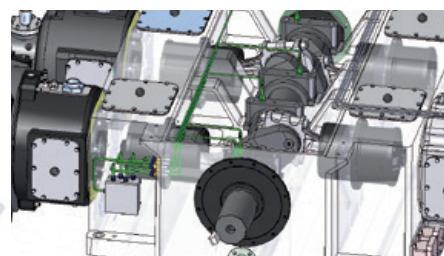

# MARKETS AND EXPERIENCE

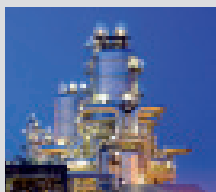

## PETROCHEMICAL

Gas compressors for all phases of the treatment of crude oil: exploration (upstream), transport (midstream), refining (downstream) and treatment of the gases for the petrochemical industry.

ABC has supplied more than 1.000 small and medium size compressor sets worldwide, working closely with well-known engineering companies, with EPCs and end users.

### GASES

- Air, natural gas, hydrocarbons, aromatics, alkanes, nafta, etc.
- H<sub>2</sub>S below 5.000 ppm.

### PROCESSES

- Refining.
- Gas transport.
- Petrochemical.

### FEATURES

- Up to 150 bar.
- Up to 1.200 kW.

### STANDARDS

- API 618.
- Pulsation analysis.

### OTHERS

- Oil-free or lubricated.
- Condensate control in saturated gases.
- Control of flammable gas emissions (nitrogen purge).
- Instrumentation (ATEX) for safety and predictive maintenance.
- V-belt or direct coupling.
- Low and medium voltage panels.
- Cooling towers or air coolers.



▲ 3EHP-4-GT  
Process Gas

- Equipment in ATEX/NEMA classified areas.

## BEST PRACTICES

COUNTRY	China	Spain	Russia	USA
COMPRESSOR MODEL	3EHP-4-GT	1EHP-4-GT	4EHP-4-LGT	2HA-2-TER-GT
GAS	Process Gas	Hydrogen	Hydrogen	Sulphur dioxide
NUMBER OF STAGES	3	1	4	2
NUMBER OF CYLINDERS	4	4x450	4	2
SIZE OF CYLINDERS (mm)	2x370/300/210	450	580/370/210/130	310/185
STROKE (mm)	200	200	200	150
SPEED (RPM)	600	422	476	521
CAPACITY (Nm <sup>3</sup> /h)	7.000	4.800	2.200	500
MOTOR (kW)	815	346	500	88
SUCTION PRESSURE (Bar)	3,0	0,0	0,1	0,0
DELIVERY PRESSURE (Bar)	38,0	3,0	65,0	4,6



## COGENERATION / NATURAL GAS

Compressors for the transport and pressure lifting of natural gas to feed gas turbines and engines.

ABC has more than 200 natural gas compressors in different generation and cogeneration plants. Its long experience, together with the close relationship with the main global machine manufacturers, guarantees the optimal compressor configuration to the changing supply conditions of the natural gas, in order to ensure reliable performance of engines and gas turbines.

### GASES

- Natural gas from industrial or residential grids.

### INDUSTRIAL SECTORS

- Paper mills, tiles, hospitals, energy, pneumatic, petrochemical, aeronautics, food industry, glass, pharmaceutical.

### FEATURES

- Up to 70 bar.
- Up to 1.100 kW.

### CONFIGURATION

- For low compression rates, one or two compression stages, with one or more compressors in parallel can be chosen.
- For higher rates, even two compressors in series.

### OTHERS

- V-belt or direct coupling.
- Low and medium voltage power panels.
- Cooling towers or air coolers.
- Guaranteed consumptions and flows.
- Equipment in ATEX/NEMA classified areas.

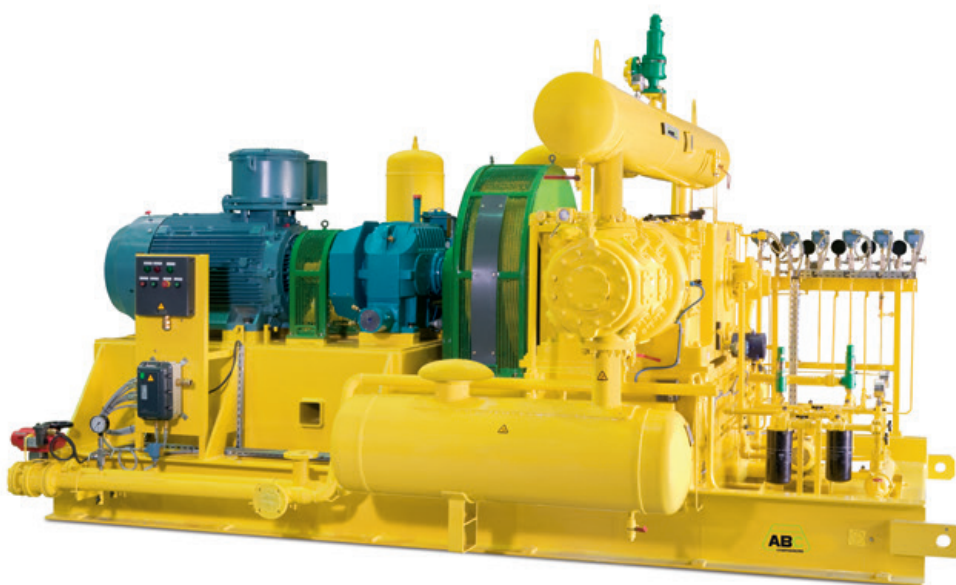

▲ 1EHP-2-GT/175  
Natural Gas

### PRESSURE CONTROL

- The customized combination of piping, bypass valves, constant pressure valves and suction and delivery tanks assures the stability of the inlet pressure to the turbine.

## BEST PRACTICES

COUNTRY	Colombia	Mexico	Spain	England
COMPRESSOR MODEL	1EHA-2-GT/140	1EHP-6-GT	1EHP-2-GT/175	1EHA-4-GT
GAS	Natural Gas	Natural Gas	Natural Gas	Natural Gas
NUMBER OF STAGES	1	1	1	1
NUMBER OF CYLINDERS	2	6	2	4
SIZE OF CYLINDERS (mm)	140	6x230	175	4x310
STROKE (mm)	150	200	200	150
SPEED (RPM)	387	461	465	480
CAPACITY (Nm <sup>3</sup> /h)	2.300	44.616	13.000	2.520
MOTOR (kW)	36	1.150	310	132
SUCTION PRESSURE (Bar)	12,8	18,45	30,0	0,2
DELIVERY PRESSURE (Bar)	22,0	32,15	46,0	2,5



## INDUSTRIAL GASES

Compressors for a wide range of industrial gases: nitrogen, argon, hydrogen, helium, carbon dioxide...

From more than 30 years, ABC has supplied compressors for the separation, transport and storage of air individual gases (by means of PSA or VPSA, membranes or similar), as well as hydrocarbons or natural gas reforming, and syngas treatment, among others.

### GASES

- All industrial gases apart from oxygen and acetylene.

### PROCESSES

- Air separation: cryogenic, pressure swing adsorption (PSA or VPSA) and membrane separation.
- Hydrocarbons reformation.
- Transport and storage of industrial gases.

### FEATURES

- Up to 150 bar.
- Up to 600 kW.

### CONFIGURATION

- Oil-free compressors.

### OTHERS

- V-belt or direct coupling.
- Low and medium voltage power panels.
- Cooling towers or air coolers.
- Equipment in ATEX/NEMA classified areas.
- Equipment in European Directive 2006-95/NEC non classified areas.

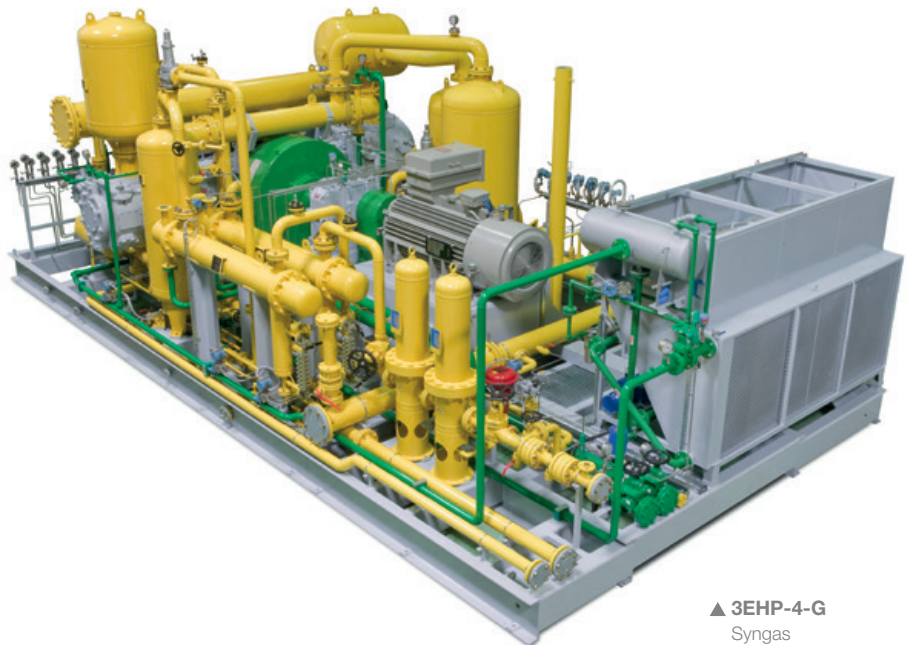

▲ 3EHP-4-G  
Syngas

## BEST PRACTICES

COUNTRY	Spain	USA	South Africa	China
COMPRESSOR MODEL	3EHP-4-G	1EHA-1-GT	1EHA-2-GT	2EHA-2-GT
GAS	Syngas	Hydrogen	Carbon Dioxide	Nitrogen
NUMBER OF STAGES	3	1	1	2
NUMBER OF CYLINDERS	4	1	2	2
SIZE OF CYLINDERS (mm)	580/370/2x145	75	2x105	140/105
STROKE (mm)	200	150	150	150
SPEED (RPM)	397	369	562	474
CAPACITY (Nm <sup>3</sup> /h)	1.844	502	816	550
MOTOR (kW)	315	11	55	55
SUCTION PRESSURE (Bar)	0,1	26,9	6,5	5,0
DELIVERY PRESSURE (Bar)	17,7	39,3	23,2	28,0

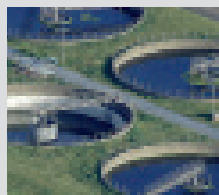

## WASTE TREATMENT / BIOGAS

Air compressors for the treatment of residential wastage, as well as biogas units from different origins (agricultural, forest...), for its cleaning (biomethane) and/or transport.

ABC has manufactured compressor sets for multiple industries: from the treatment of industrial water by oxidation, processing of biogas coming from water and residential waste, CO<sub>2</sub> and H<sub>2</sub>S separation from methane...

### GASES

- Air for waste treatment.
- Biogas (transport and treatment).

### PROCESSES

- Treatment of waste, industrial and residential waters.
- Transport and cleaning of biogas.

### FEATURES

- Up to 110 bar (water waste).
- Around 10 bar (biogas treatment).
- Lubricated compressors for the treatment of saturated biogas.

### OTHERS

- Condensate control in saturated gases.
- Control of flammable gases by means of inert gas injection (nitrogen purge).
- Cooling towers or air coolers.
- Equipment in ATEX/NEMA classified areas.
- Equipment in European Directive 2006-95/NEC non classified areas.



▲ 2EHA-2-BIS-G  
Biogas

## BEST PRACTICES

COUNTRY	Spain	Peru	France	Kuwait
COMPRESSOR MODEL	2EHA-2-BIS-G	5EHA-6-LT	6HA-6-TER-LT	2EHA-2-LT
GAS	Biogas	Air	Air	Air
NUMBER OF STAGES	2	5	6	2
NUMBER OF CYLINDERS	2	6	6	2
SIZE OF CYLINDERS (mm)	280/160	2x160/160/105/75/60	310/185/125/75/60/50	105/75
STROKE (mm)	150	150	150	150
SPEED (RPM)	750	380	746	386
CAPACITY (Nm <sup>3</sup> /h)	553	195	696	220
MOTOR (kW)	90	75	250	41,4
SUCTION PRESSURE (Bar)	0,0	0,0	0,0	4,8
DELIVERY PRESSURE (Bar)	10,0	92,0	150,0	31,0



## PET BLOWING / CO<sub>2</sub> RECOVERY

ABC has been a pioneer in the supply of compressor sets for the beverage industry.

High pressure compressors for PET bottle blowing and for CO<sub>2</sub> recovery in breweries, has long been a focus for ABC. From the 80s, ABC has supplied more than 2.500 compression units in 120 countries, in close cooperation with converters, bottlers and engineering companies.

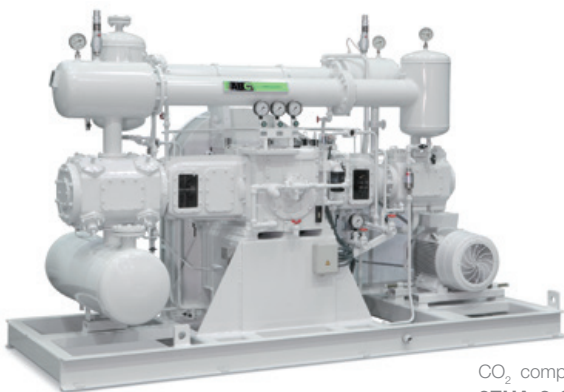

CO<sub>2</sub> compressor  
▲ 2EHA-2-GT

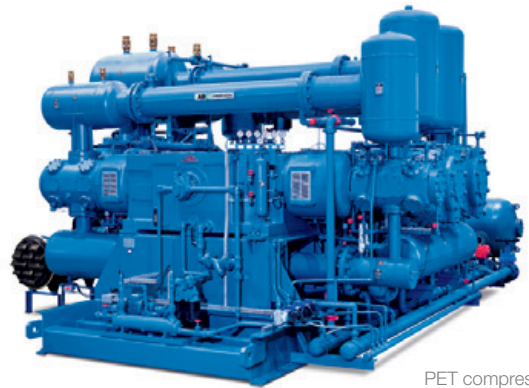

PET compressor  
▲ 4HP-6-LT

For additional information, browse our **PET BLOWING AND CO<sub>2</sub> RECOVERY** catalogue.



## OTHER APPLICATIONS

ABC has been awarded the full confidence of the market by responding to the requirements of its customers with a full range of customised solutions for each application.

The market orientation, experience, flexibility and commitment of ABC are proven by the development of new compressor sets for high tech industries, becoming a reliable long-term partner with their customers.

### GASES

- Nitrogen, high pressure air, carbon dioxide, hydrogen.

### PROCESSES

- Autoclave.
- High pressure air or gas injection for enhanced oil recovery.
- Capture and storage of CO<sub>2</sub> (CCS).
- Thermosolar energy.
- Fat hydrogenation.

### R&D&i

- Compressors are customized to meet clients' requirements and processes.

### OTHERS

- V-belt or direct coupling.
- Low and medium voltage panels.
- Cooling towers or air coolers.
- Oil-free or lubricated.
- Condensate control in saturated gases.
- Equipment in ATEX/NEC/NEMA classified areas.

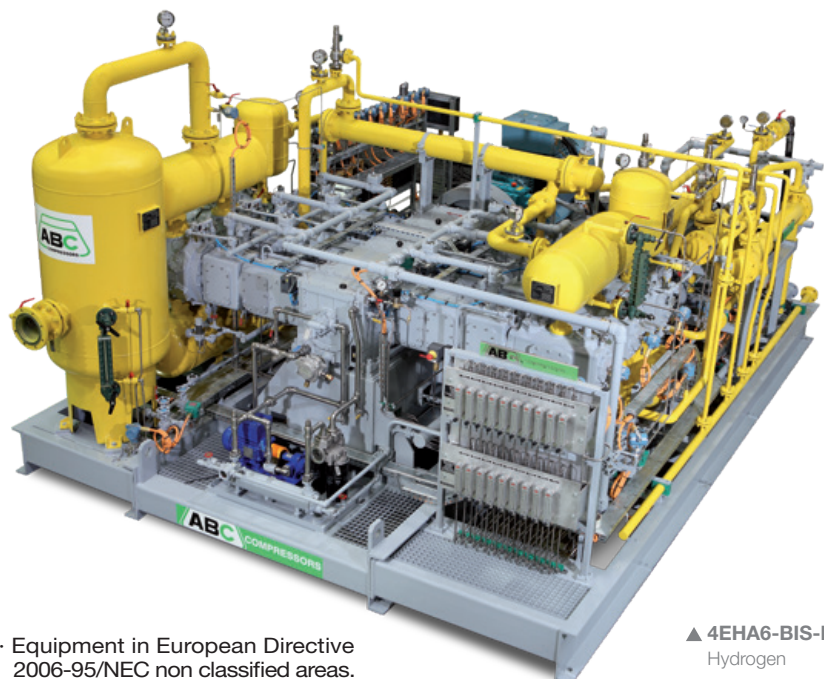

· Equipment in European Directive 2006-95/NEC non classified areas.

▲ 4EHA6-BIS-L-GT  
Hydrogen

# ABILITY services

After more than 60 years in the market, ABC works to strengthen long-term relationships with clients, **supplying not only the best customized products, but also the complete service package for their whole life cycle.**

## ABILITY NETWORK

Through a wide network of service offices in more than 20 countries, with more than **100 field technicians and stock of spares** strategically distributed throughout the world, ABC ensures the best technical support for the start-up, maintenance and monitoring of compressors.

## ABILITY CONTRACT

In order to grant the best long-term operating guidelines of the compressors and to keep the maintenance cost controlled from the very beginning, ABC offers **"FULL SERVICE"**, maintenance contracts, with extended **guarantee up to five years.**

## ABILITY EYE

ABC considers it important to help clients monitor their international compressor network quickly and efficiently. Consequently, the ABILITY Eye **REMOTE CONTROLLER**, with its three levels of surveillance, becomes the perfect tool to keep the compressor room under control.

**ABILITY Services** cover the **services from the initial design of compressor, its start-up to its operation**, providing the following range of services, as well as technical solutions:

## ABILITY IMPROVER

Its products and services are aimed at **optimizing clients' air or gas compression system.** Improvement of regulation system, systems for coordination of batteries of machines, upgrading of compressors, energy saving methods, consultancy and plant audits.

## ABILITY ACADEMY

ABC offers clients and field specialists **complete training programs**, to ensure that only the best technical guidelines are used when diagnosing and operating the compressors.



Energy audit

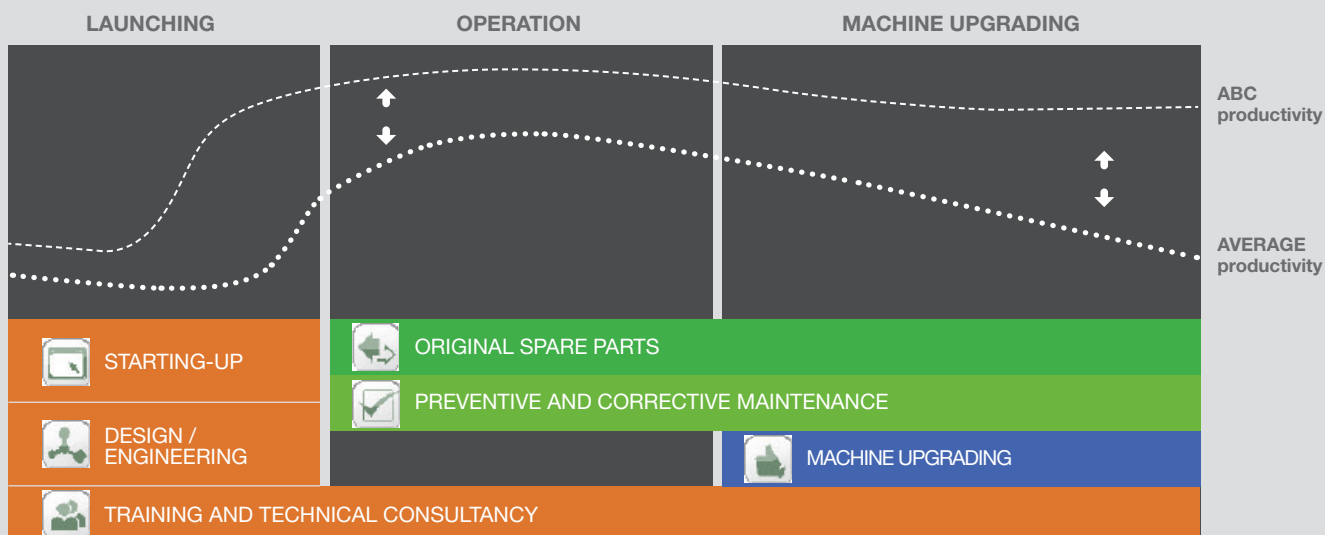

For additional information browse our Service Catalogue or visit our website [www.abc-compressors.com](http://www.abc-compressors.com)

## HEADQUARTER

Eibar

Polígono Azitain nº 6 P.O.Box 87  
20600 EIBAR (Guipúzcoa) SPAIN

Tel.: +34 943 820 400

Fax: +34 943 820 235

abc@abc-compressors.com

Contact with our **INTERNATIONAL NETWORK**  
through:

[www.abc-compressors.com](http://www.abc-compressors.com)

# RELIABLE BEYOND LIMITS



09/2013



ARIZAGA, BASTARRICA Y CIA, S.A.

**TOTAL QUALITY**

ISO 9001

ISO 14001

OHSAS 18001